

Assembly instructions for

KING BED

B-3410-8-KH/B-3410-8-QKL/B-3410-8-KF/B-3410-8-KR

Caution : Please read instructions thoroughly before unpacking assembly parts. Sharp, exposed staple tips can cause injury, therefore, for your protection, please remove any exposed staples used in packing.

1. We recommend that you should assemble this product with the assistance of another person; this will make assembly easier, and will help to eliminate damage to the product or injury to persons during assembly.
2. Be sure to check all packing materials carefully for small parts that may have come loose inside the carton during shipment.
3. Please do not over tighten screws or bolts.
4. Please put all parts on a non-abrasive floor before assembly, and follow the assembly steps to assemble your newly purchased product correctly and efficiently.

PARTS LIST			
NO.	PART DESC	CODE	QTY
A	KING HEADBOARD	B-3410-8-KBH	1
B	QUEEN & KING LEG	B-3410-8-QKL	2
C	KING FOOTBOARD	B-3410-8-KBF	1
C1	KING & QUEEN LEFT SIDE RAIL	B-3410-8-KQSRL	1
C2	KING & QUEEN RIGHT SIDE RAIL	B-3410-8-KQSRR	1
D1	KING BED ROLL SLAT	B-3410-8-KBSLT	12
D2	KING BED SLAT SUPPORT LEG	B-3410-8-BDSPL	8

HARDWARE LIST			
NO.	HARDWARE DESC	CODE	QTY
1	Bolt M8 x 60mm	B-3410-KBHW	16
2	Bolt M8 x 20mm		4
3	Flat washer 5/16" x 22mm		20
4	Allen key M5 x 67mm		1
5	Wooden dowel \varnothing 10 x 30mm		4
6	Screw M4 x 30mm		24

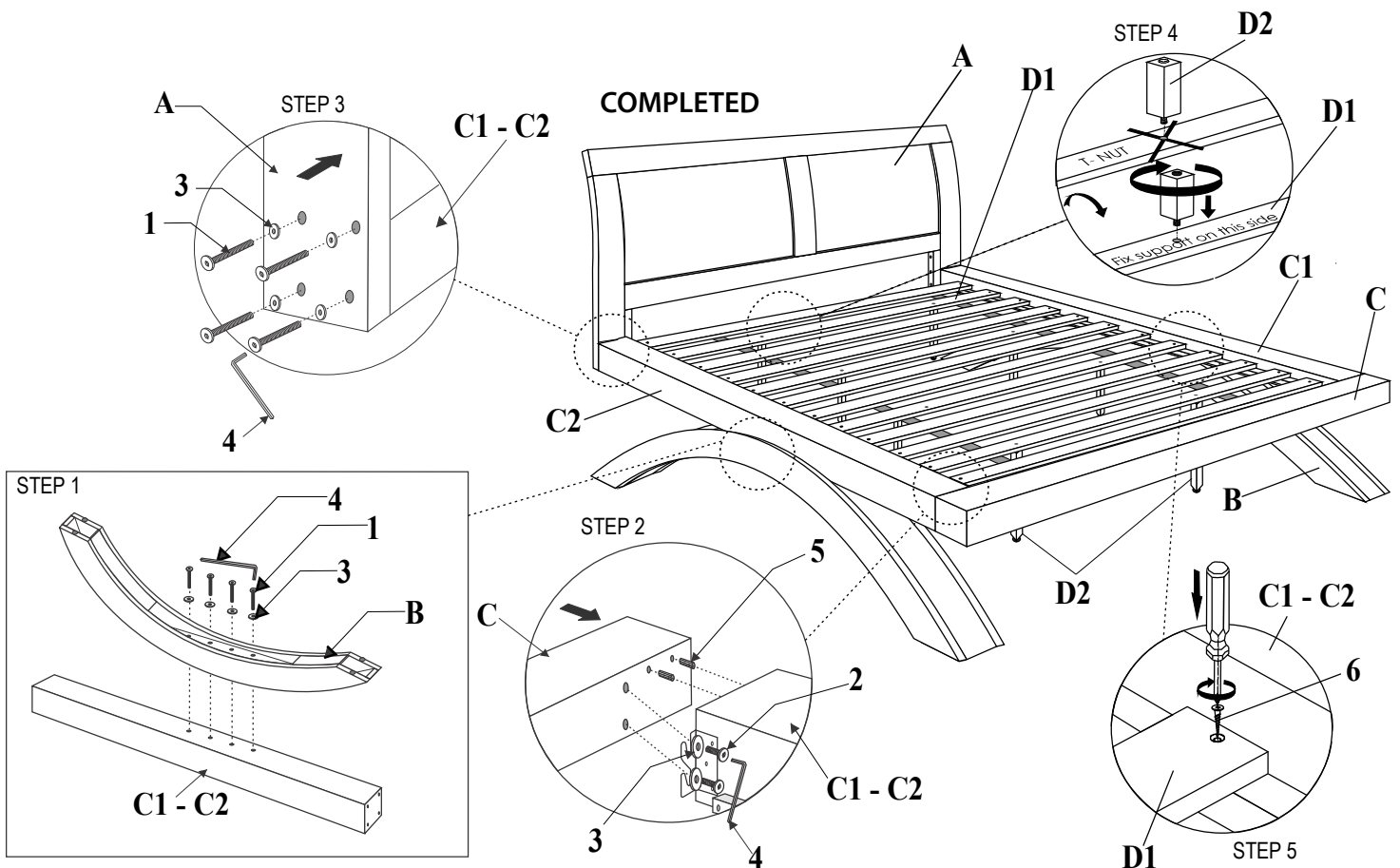

Assembly instructions for

QUEEN BED

B-3410-8-QH/B-3410-8-QKL/B-3410-8-QF/B-3410-8-QR

Caution : Please read instructions thoroughly before unpacking assembly parts. Sharp, exposed staple tips can cause injury, therefore, for your protection, please remove any exposed staples used in packing.

1. We recommend that you should assemble this product with the assistance of another person; this will make assembly easier, and will help to eliminate damage to the product or injury to persons during assembly.
2. Be sure to check all packing materials carefully for small parts that may have come loose inside the carton during shipment.
3. Please do not over tighten screws or bolts.
4. Please put all parts on a non-abrasive floor before assembly, and follow the assembly steps to assemble your newly purchased product correctly and efficiently.

PARTS LIST			
NO.	PART DESC	CODE	QTY
A	QUEEN HEADBOARD	B-3410-8-QBH	1
B	QUEEN & KING LEG	B-3410-8-QKL	2
C	QUEEN FOOTBOARD	B-3410-8-QBF	1
C1	KING & QUEEN LEFT SIDE RAIL	B-3410-8-KQSRL	1
C2	KING & QUEEN RIGHT SIDE RAIL	B-3410-8-KQSRR	1
D1	QUEEN BED ROLL SLAT	B-3410-8-QBSLT	12
D2	QUEEN BED SLAT SUPPORT LEG	B-3410-8-BDSPL	4

HARDWARE LIST			
NO.	HARDWARE DESC	CODE	QTY
1	 Bolt M8 x 60mm	B-3410-QBHW	16
2	 Bolt M8 x 20mm		4
3	 Flat washer 5/16" x 22mm		20
4	 Allen key M5 x 67mm		1
5	 Wooden dowel \varnothing 10 x 30mm		4
6	 Screw M4 x 30mm		24

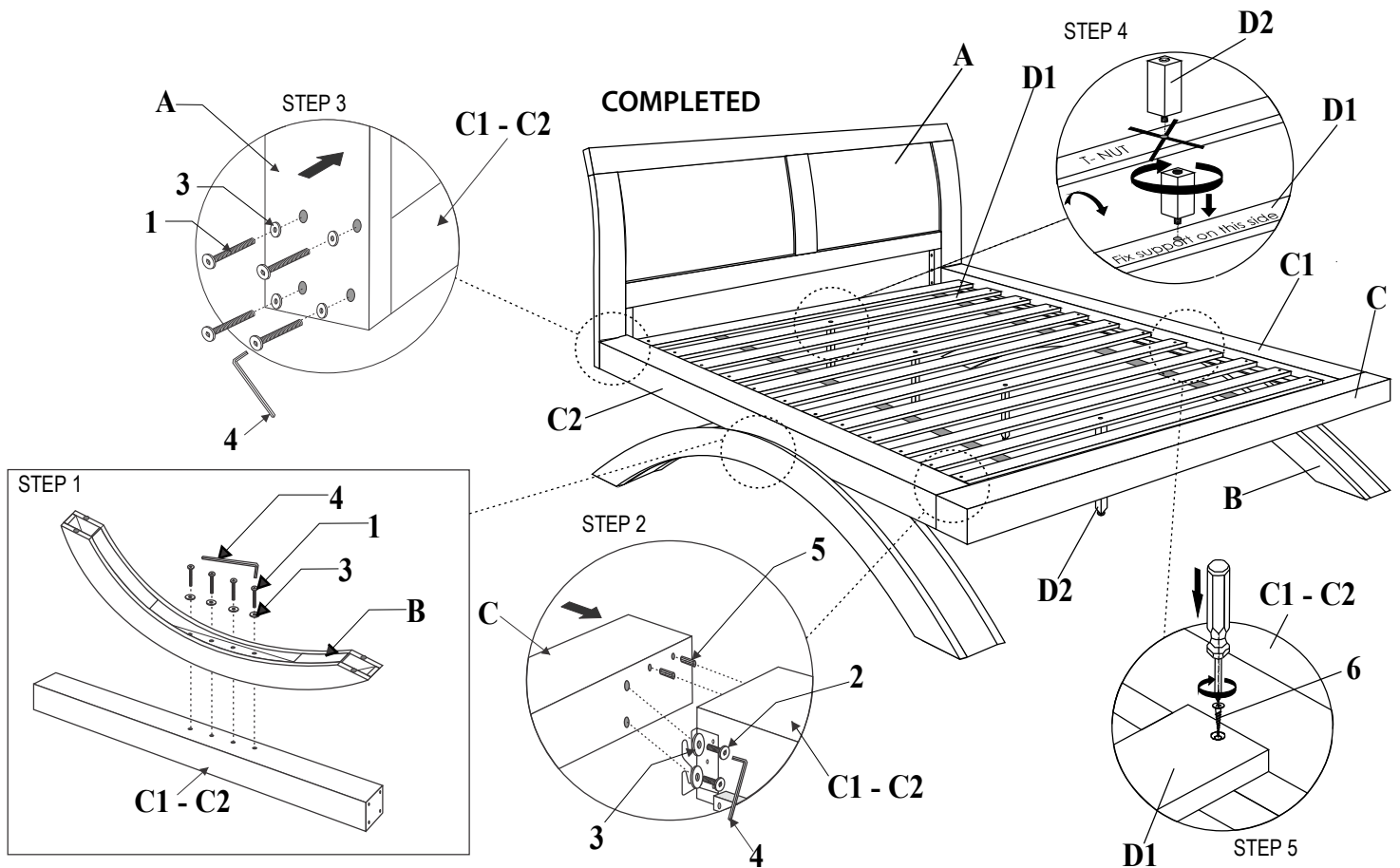

Assembly instructions for

FULL BED

B-3410-8-FH/B-3410-8-TFL/B-3410-8-FF/B-3410-8-FR

Caution : Please read instructions thoroughly before unpacking assembly parts. Sharp, exposed staple tips can cause injury, therefore, for your protection, please remove any exposed staples used in packing.

1. We recommend that you should assemble this product with the assistance of another person; this will make assembly easier, and will help to eliminate damage to the product or injury to persons during assembly.
2. Be sure to check all packing materials carefully for small parts that may have come loose inside the carton during shipment.
3. Please do not over tighten screws or bolts.
4. Please put all parts on a non-abrasive floor before assembly, and follow the assembly steps to assemble your newly purchased product correctly and efficiently.

PARTS LIST			
NO.	PART DESC	CODE	QTY
A	FULL HEADBOARD	B-3410-8-FBH	1
B	TWIN & FULL LEG	B-3410-8-TFL	2
C	FULL FOOTBOARD	B-3410-8-FBF	1
C1	FULL & TWIN LEFT SIDE RAIL	B-3410-8-FTSRL	1
C2	FULL & TWIN RIGHT SIDE RAIL	B-3410-8-FTSRR	1
D1	FULL BED ROLL SLAT	B-3410-8-FBSLT	12
D2	FULL BED SLAT SUPPORT LEG	B-3410-8-BDSPL	4

HARDWARE LIST			
NO.	HARDWARE DESC	CODE	QTY
1	Bolt M8 x 60mm	B-3410-FBHW	16
2	Bolt M8 x 20mm		4
3	Flat washer 5/16" x 22mm		20
4	Allen key M5 x 67mm		1
5	Wooden dowel \varnothing 10 x 30mm		4
6	Screw M4 x 30mm		24

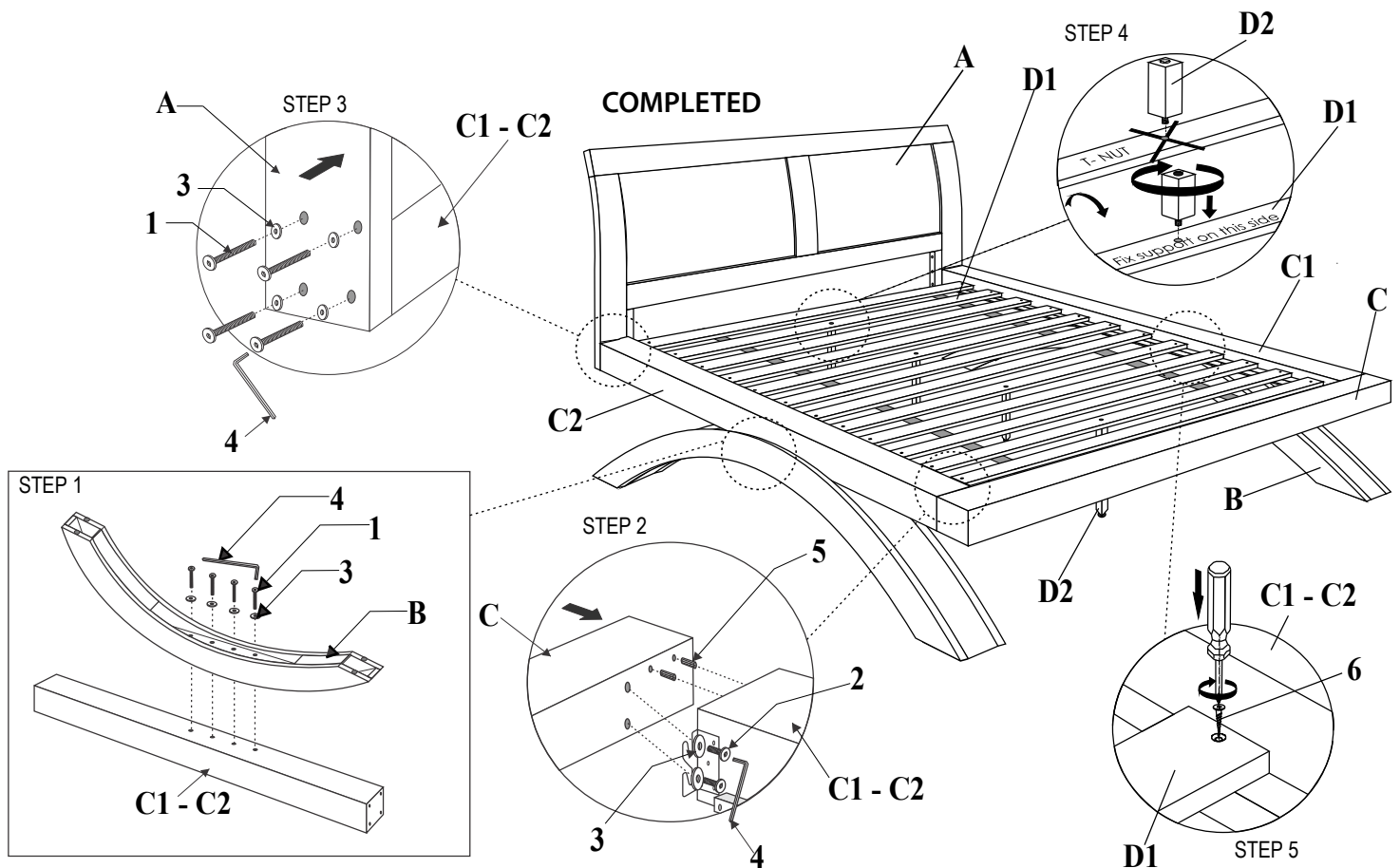

Assembly instructions for



TWIN BED

B-3410-8-TH/B-3410-8-TFL/B-3410-8-TF/B-3410-8-TR

Caution : Please read instructions thoroughly before unpacking assembly parts. Sharp, exposed staple tips can cause injury, therefore, for your protection, please remove any exposed staples used in packing.

1. We recommend that you should assemble this product with the assistance of another person; this will make assembly easier, and will help to eliminate damage to the product or injury to persons during assembly.
2. Be sure to check all packing materials carefully for small parts that may have come loose inside the carton during shipment.
3. Please do not over tighten screws or bolts.
4. Please put all parts on a non-abrasive floor before assembly, and follow the assembly steps to assemble your newly purchased product correctly and efficiently.

PARTS LIST			
NO.	PART DESC	CODE	QTY
A	TWIN HEADBOARD	B-3410-8-TBH	1
B	TWIN & FULL LEG	B-3410-8-TFL	2
C	TWIN FOOTBOARD	B-3410-8-TBF	1
C1	FULL & TWIN LEFT SIDE RAIL	B-3410-8-FTSRL	1
C2	FULL & TWIN RIGHT SIDE RAIL	B-3410-8-FTSRR	1
D1	TWIN BED ROLL SLAT	B-3410-8-TBSLT	12
D2	TWIN BED SLAT SUPPORT LEG	B-3410-8-BDSPL	4

HARDWARE LIST			
NO.	HARDWARE DESC	CODE	QTY
1	 Bolt M8 x 60mm	B-3410-TBHW	16
2	 Bolt M8 x 20mm		4
3	 Flat washer 5/16" x 22mm		20
4	 Allen key M5 x 67mm		1
5	 Wooden dowel \varnothing 10 x 30mm		4
6	 Screw M4 x 30mm		24

