

## Assembly Instructions for / Instruction D'assemblage pour



























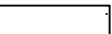
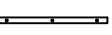

KING HB W/LED LIGHT / TÊTE DE LIT TRÈS GRAND FORMAT AVEC ÉCLAIRAGE LED  
 KING FB -14 SLATS / KING PIED DE LIT / 14 LATTES  
 KING FB - STORAGE DRAWER / TIROIR DE RANGEMENT  
 CAL KING SIDE RAILS / MONTANTS GRAND FORMAT / TRÈS GRAND FORMAT  
 TN600KH/TN600KF  
 TN600KS/TN600CKR

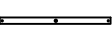
Caution : Please read instruction thoroughly before unpacking assembly parts. Sharp, exposed staple tips can cause injury, therefore, for your protection, please remove any exposed staples used in packing.

1. We recommend that you should assemble this product with the assistance of another person; this will make assembly easier, and will help to eliminate damage to the product or injury to persons during assembly.
2. Be sure to check all packing materials carefully for small parts that may have come loose inside the carton during shipment.
3. Please do not over tighten screw or bolts.
4. Please put all parts on a non-abrasive floor before assembly, and follow the assembly steps to assemble your newly purchased product correctly and efficiently.

Attention: Veuillez lire attentivement les instructions avant de débiter les pièces d'assemblage. Les pointes pointues et décontractées peuvent Causer des blessures, donc, pour votre protection, retirez les agrafes exposées utilisées dans l'emballage.

1. Nous vous recommandons d'assembler ce produit avec l'aide d'une autre personne; Cela fera Faciliter l'assemblage, et aider à éliminer les dommages causés au produit ou blesser les personnes pendant l'assemblage.
2. Assurez-vous de vérifier attentivement tous les matériaux d'emballage pour les petites pièces qui peuvent se perdre à l'intérieur du carton Pendant l'expédition.
3. Ne pas serrer trop les vis ou les boulons.
4. Partez toutes les pièces sur un plancher non abrasif avant l'assemblage et suivez les étapes de montage pour assembler votre Produit nouvellement acheté correctement et efficacement.

PART LIST					HARDWARE LIST				
NO	NAME	PART	CODE	QTY	NO	NAME	PART	CODE	QTY
A	Headboard			1pc	1	Allen key		KBHW	1pc
B	Footboard			1pc	2	JCBC 16mm			2pcs
C	Bun Foot			2pcs	3	JCBC 35mm			9pcs
D	Side Rail			2pcs	4	JCBC 60mm			5pcs
E	Drawer		PTN600KFDRW1	2pcs	5	M6 Spring washer			16pcs
F	Drawer Bottom Panel with Slide		PTN600KFDPNL	2pcs	6	M6 Flat washer			11pcs
G	Slat		PTN600KBSLT	13pcs	7	Screw 32mm			26pcs
H	Slat Support Leg (short)		PTN600BDSPL	5pcs	8	Screw 16mm			2pcs
I	Drawer Support Leg		PTN600BDSPS	1pc	9	Adjustable Leveller			6pcs
J	Slat Cover Panel		PTN600KSCPN	1pc	HARDWARE LOCATED IN FOOTBOARD BOX				
K	Center Vertical Slat		PTN600KQCSR	1pc	HARDWARE LIST				
L	Drawer Support Rail		PTN600KDSL	1pc	10	Allen key		CKBHW	1pc
M	Slat		PTN600CKSLT	1pc	11	JCBC 35mm			1pc
N	Slat Support Leg (Extra long)		PTN600CKSPL	1pc	12	JCBC 45mm			10pcs
O	Top Cap		PTN600CKRTC	2pcs	13	M6 Spring washer			11pcs
					14	M6 Flat washer			10pcs
					15	Screw 32mm			2pc
					16	Adjustable Leveller		1pc	
					HARDWARE LOCATED IN SIDE RAIL BOX				

Bun Foot cover /  
Couverture des pieds

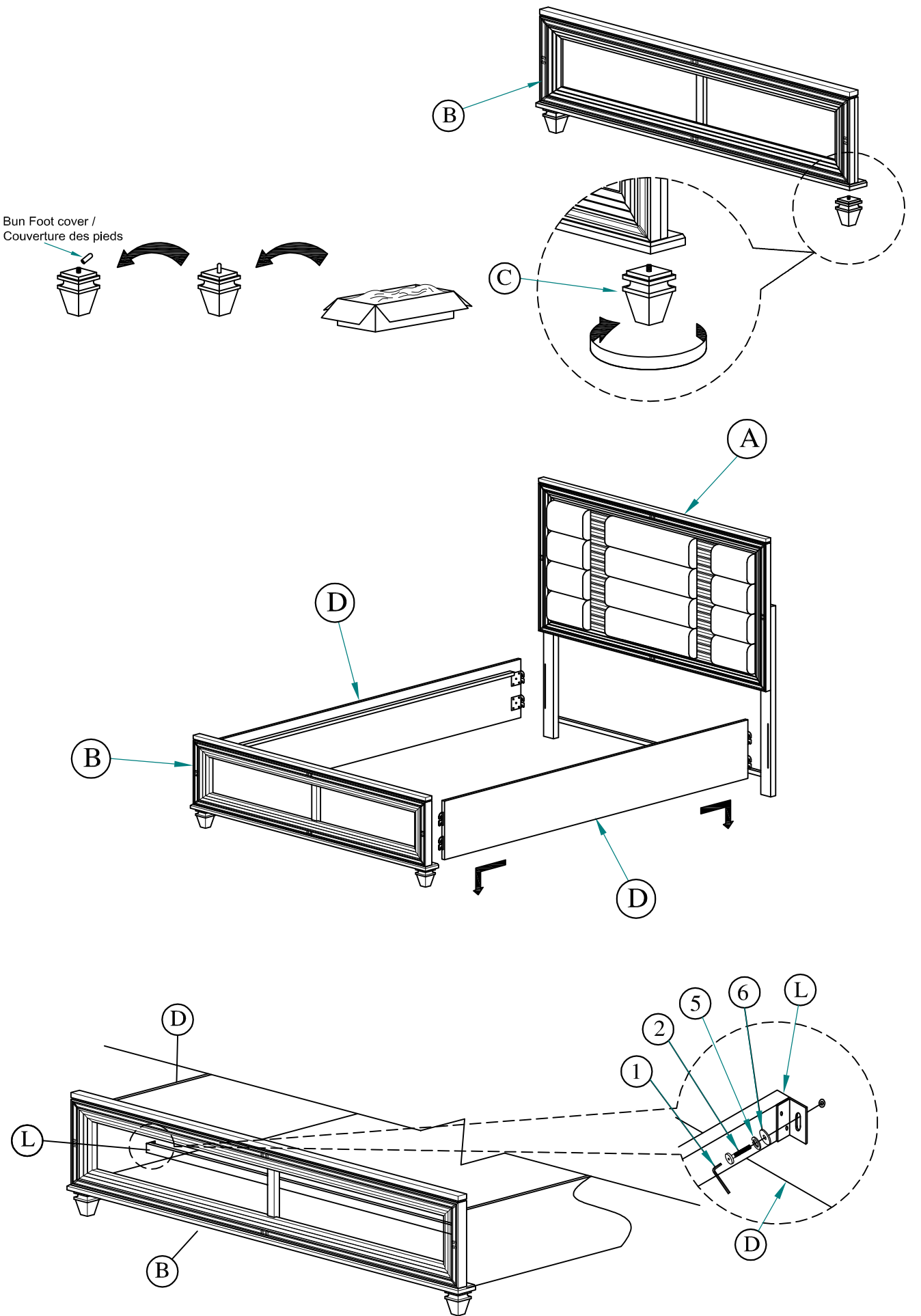

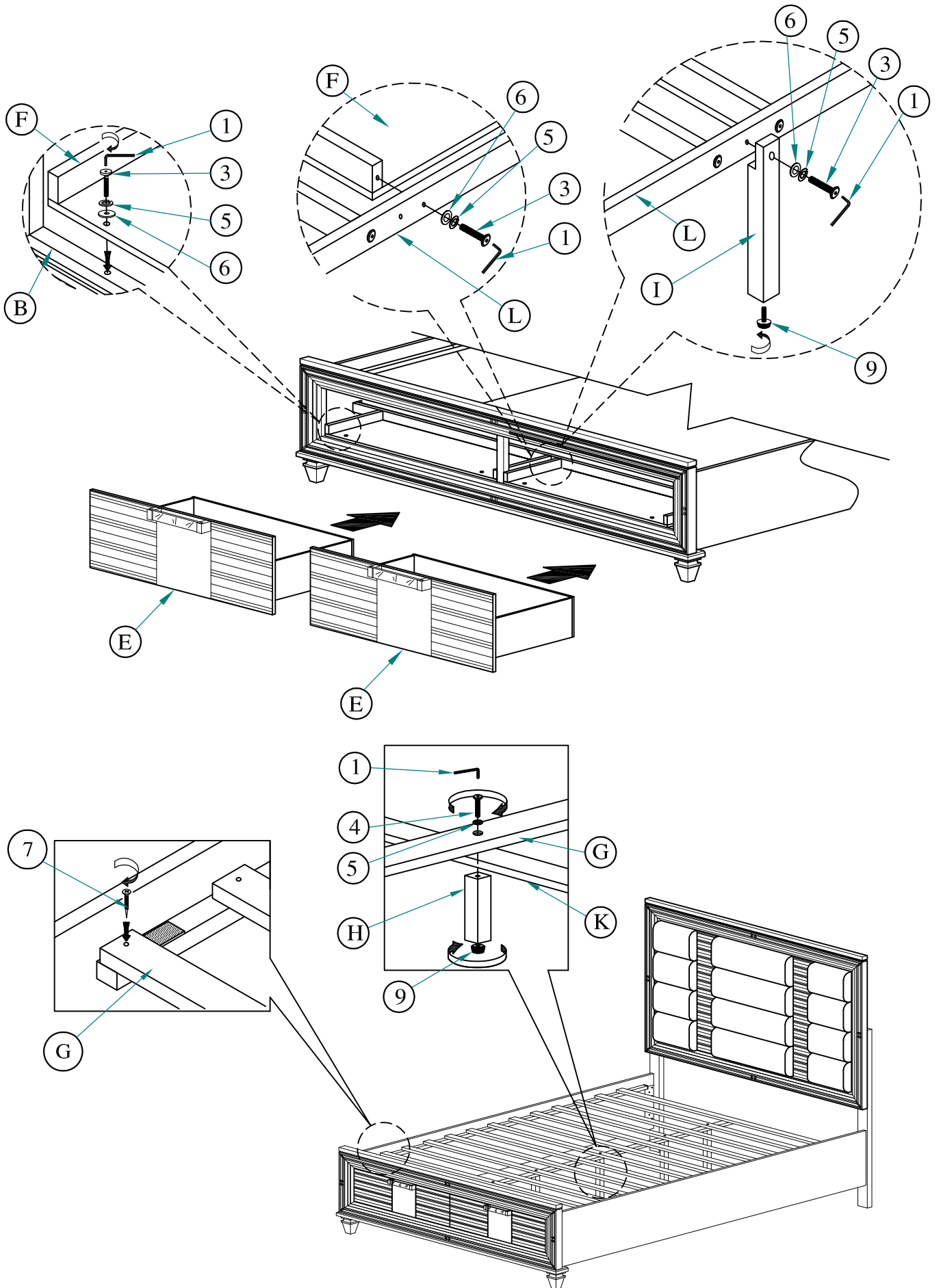

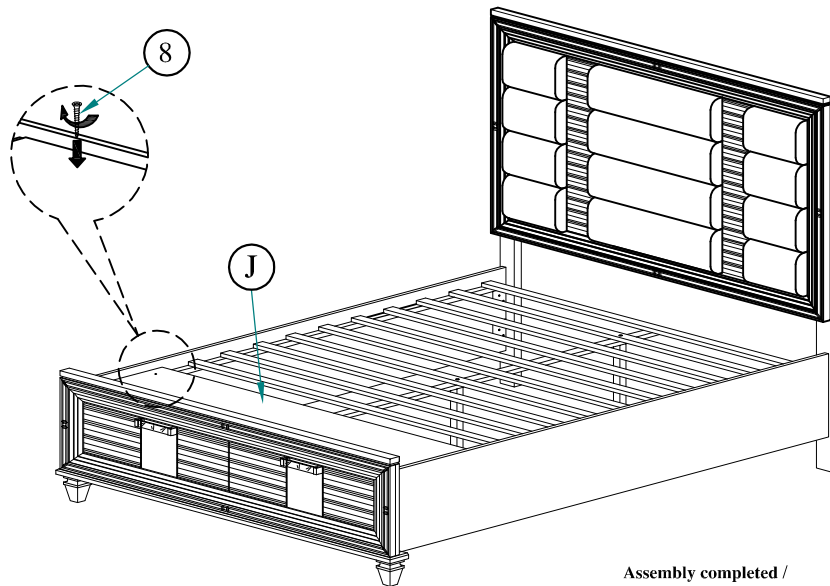
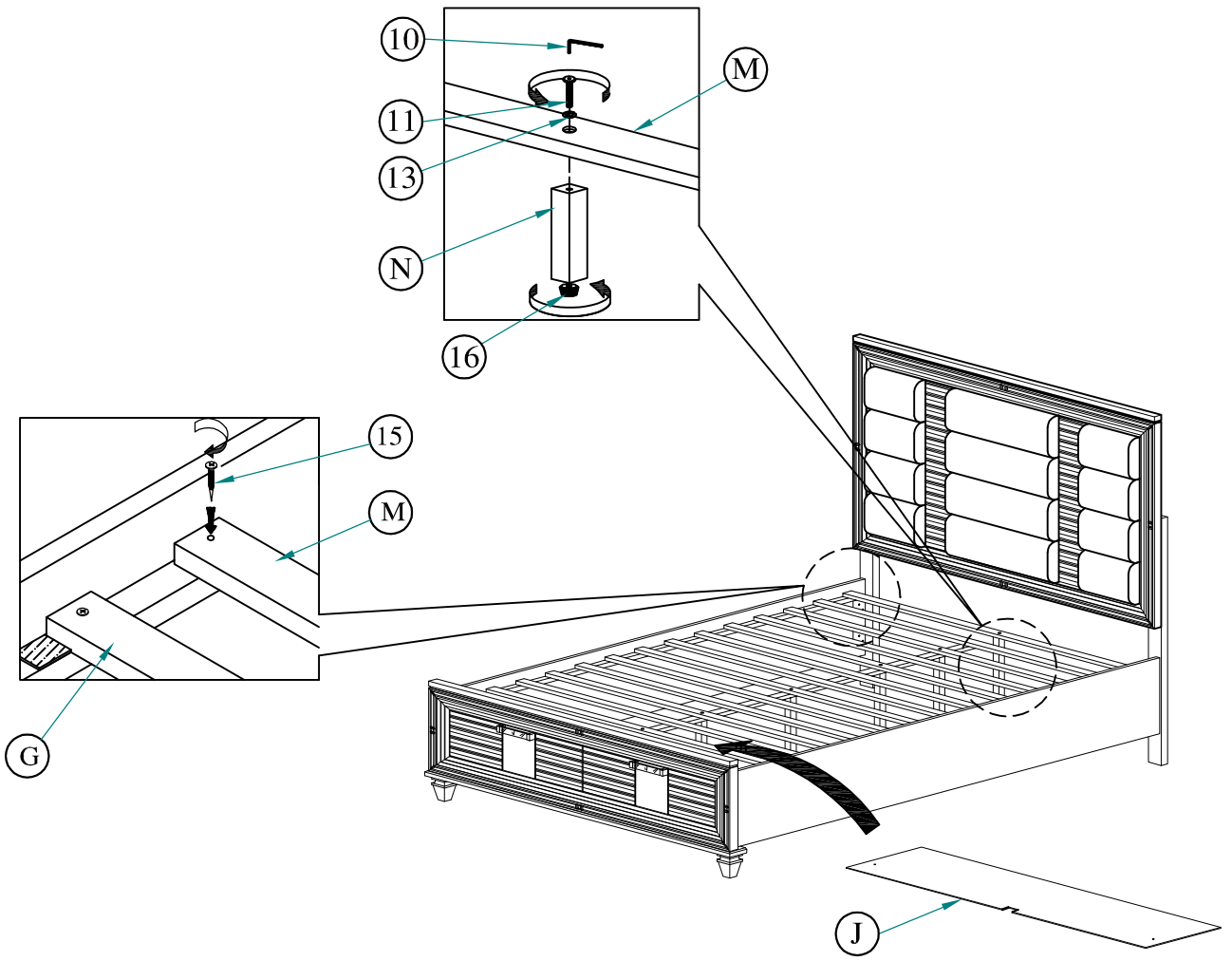

Assembly completed /  
Assemblage completé

